

Cylinder head, removing and installing

Compression pressure, checking ⇒ [Page 15-19](#)

Note:

- ◆ When installing an exchange cylinder head (with camshaft), contact surfaces between hydraulic lifter and cam must be oiled after installation.
- ◆ Plastic protectors (to protect open valves) should be removed only just before installing the cylinder head.
- ◆ If cylinder head is replaced, replace all engine coolant

1 - Intake manifold

- ◆ Removing and installing ⇒ [Page 15-9](#)
 - Tighten to lower intake manifold, then to two rear supports (items 7 and 3).
 - ◆ Disassembly and assembly
- ⇒ [Repair Manual, 2.8 Liter VR6 2V Fuel Injection & Ignition, Engine Code\(s\): AES, Repair Group 24](#)

2 - 25 Nm (18 ft. lb)

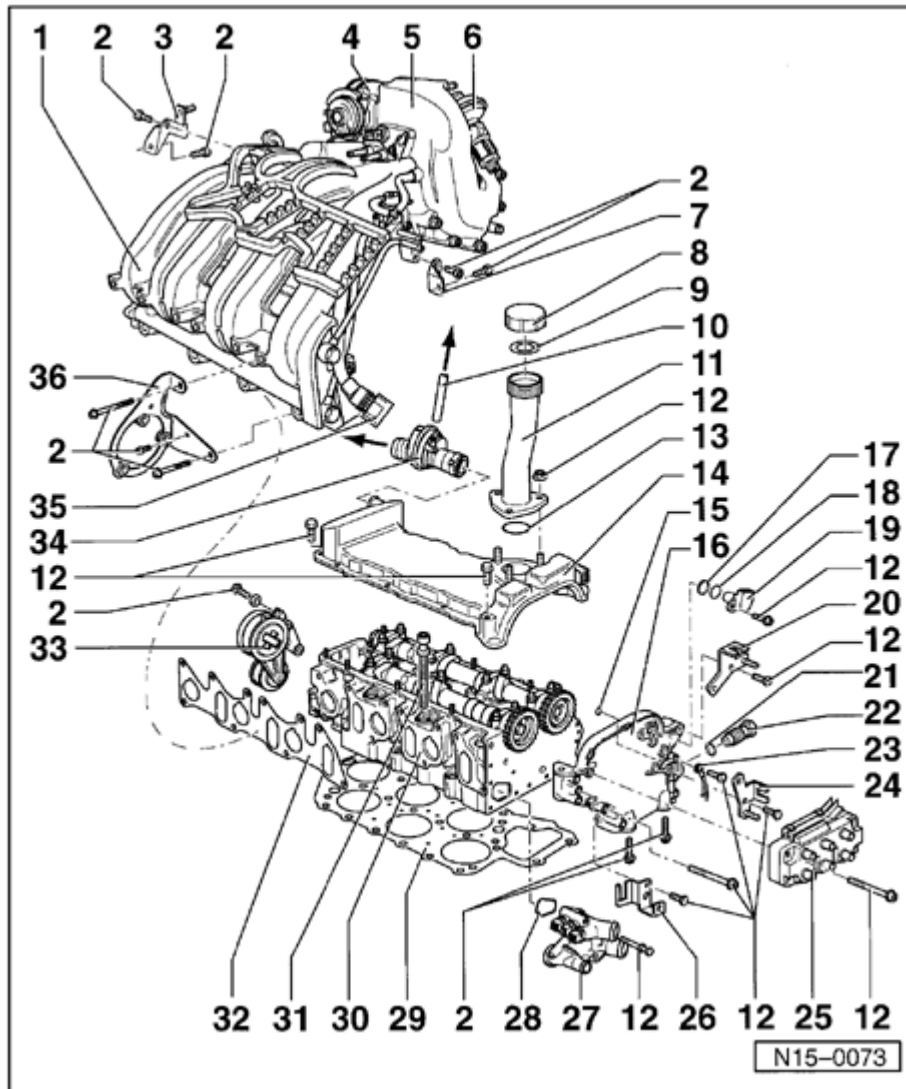

3 - Right rear support

- ◆ Between intake manifold and cylinder head cover

4 - Throttle Valve Control Module -J338-

- ◆ Heated by coolant.
- ◆ Removing and installing:

⇒ [Repair Manual, 2.8 Liter VR6 2V Fuel Injection & Ignition, Engine Code\(s\): AES, Repair Group 24](#)

5 - Connection

- ◆ Removing and installing:

⇒ [Repair Manual, 2.8 Liter VR6 2V Fuel Injection & Ignition, Engine Code\(s\): AES, Repair Group 24](#)

6 - Exhaust Gas Recirculation (EGR) valve

- ◆ ⇒ [Page 26-8](#)

7 - Left rear support

- ◆ Between intake manifold and cylinder head

8 - Cap

9 - Gasket

- Replace if damaged.

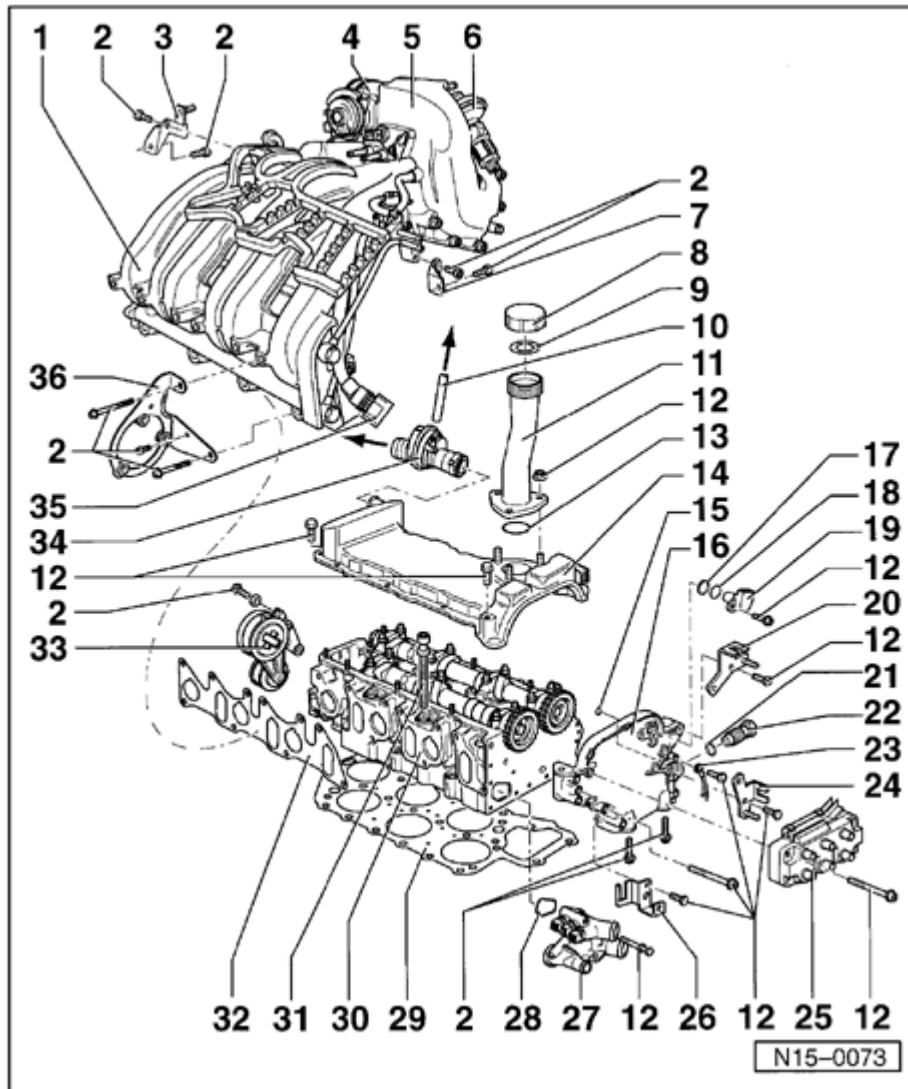

10 - Vacuum line

- ◆ To EGR valve/intake manifold junction piece ⇒ [Page 26-8](#)

11 - Oil fill tube

12 - 10 Nm (7 ft. lb)

13 - O-ring

- Replace.

14 - Cylinder head cover

- ◆ Removing and installing ⇒ [Page 15-9](#)
- Replace if damaged or leaking.

15 - O-Ring

- Replace

16 - Camshaft sprocket cover

- ◆ Can be removed and installed with cylinder head installed.
- Coat sealing surfaces with AMV 188 001 02.
- If only camshaft sprocket cover has been removed, prepare cylinder head gasket for assembly ⇒ [Fig. 2](#)

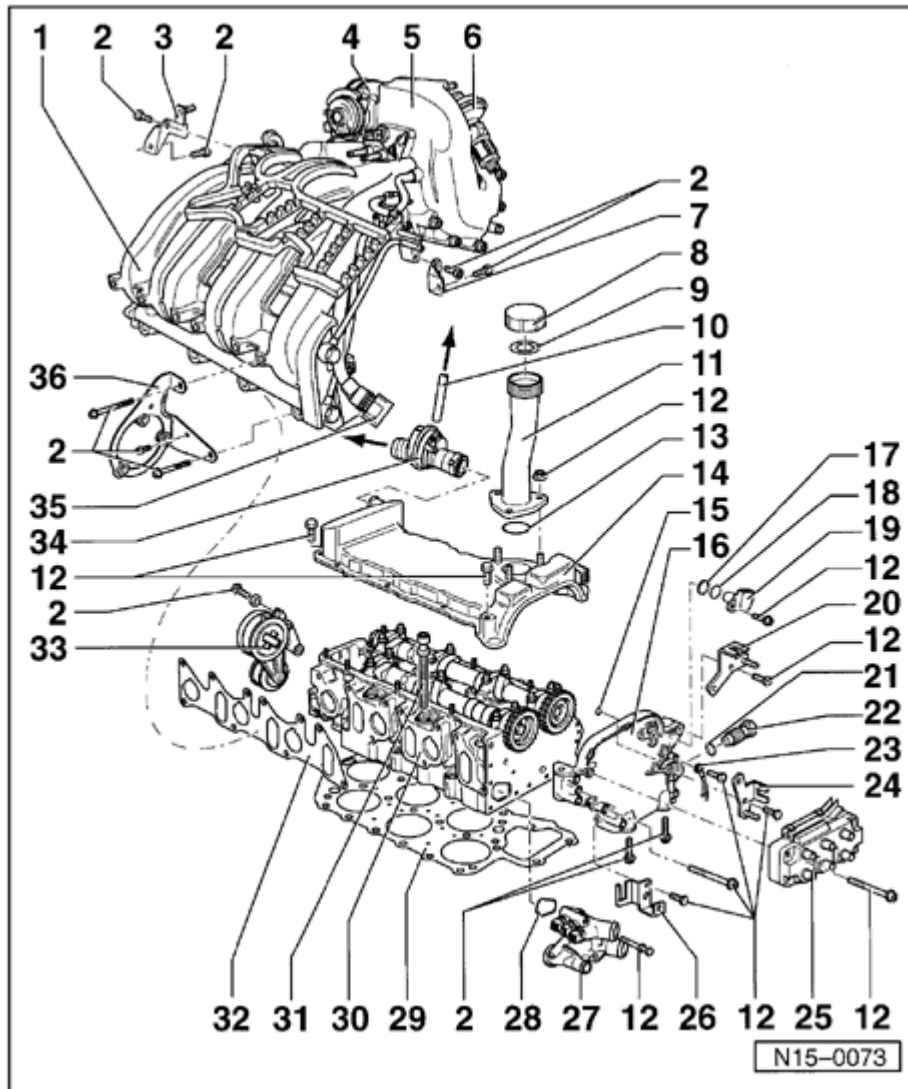

17 - Spacer ring

18 - O-Ring

- Replace.

- Lubricate before installing

19 - Camshaft Position (CMP) sensor-G40-

◆ Checking:

⇒ [Repair Manual, 2.8 Liter VR6 2V Fuel Injection & Ignition, Engine Code\(s\): AES, Repair Group 01](#)

20 - Bracket

◆ For -G98- EGR Temperature sensor, 2-pin connector ⇒ [Page 26-8](#)

CAUTION!

Only turn engine when chain tensioner is installed.

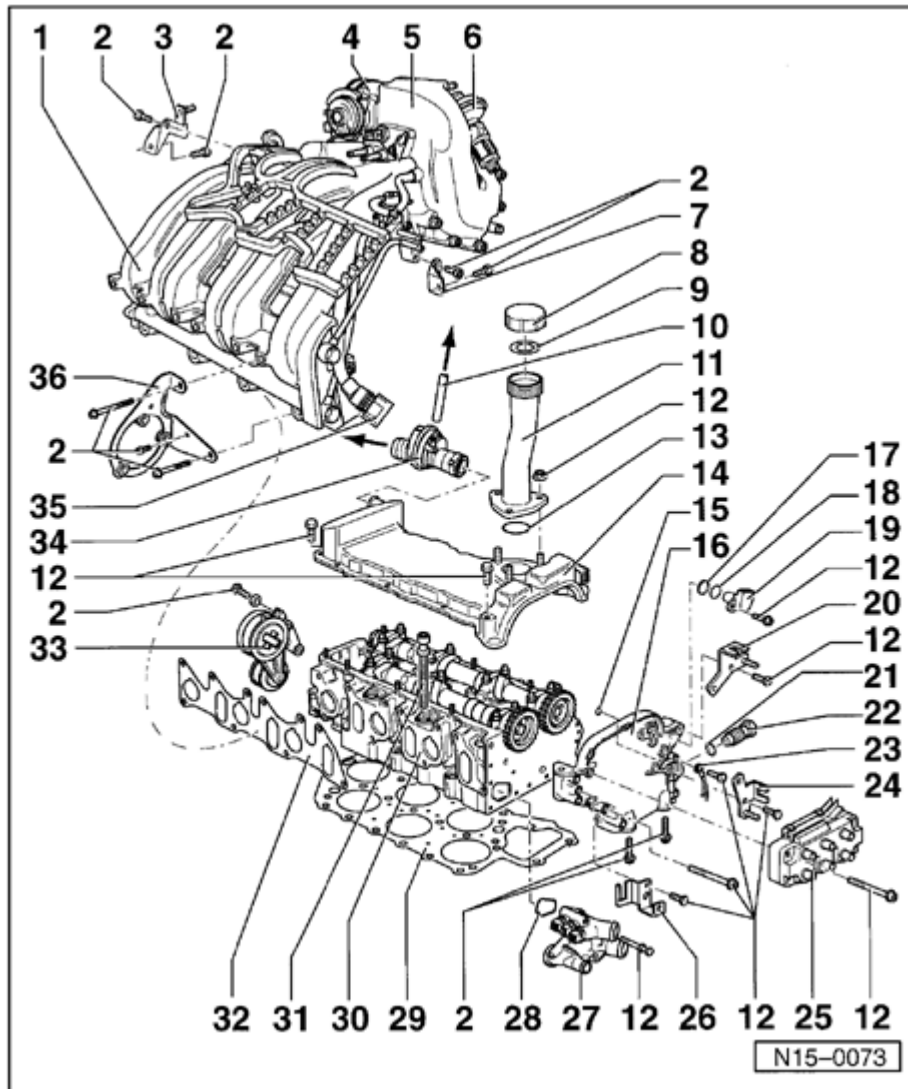

21 - O-Ring

- Replace

22 - Chain tensioner

◆ 30 Nm (22 ft. lb)

◆ For upper chain

- Bleed before installing ⇒ [Page 13-8](#) , ⇒ [Fig. 3](#)

◆ Up to engine number AES-003278 with oil drilling for double link chain.

23 - Ground connection

24 - Bracket

25 - Ignition coil -N152-*

◆ Checking:

⇒ [Repair Manual, 2.8 Liter VR6 2V Fuel Injection & Ignition, Engine Code\(s\): AES, Repair Group 28](#)

26 - Bracket

◆ For fuel injector connectors (item 35)

27 - Thermostat housing

◆ Disassembly and assembly ⇒ [Page 19-12](#)

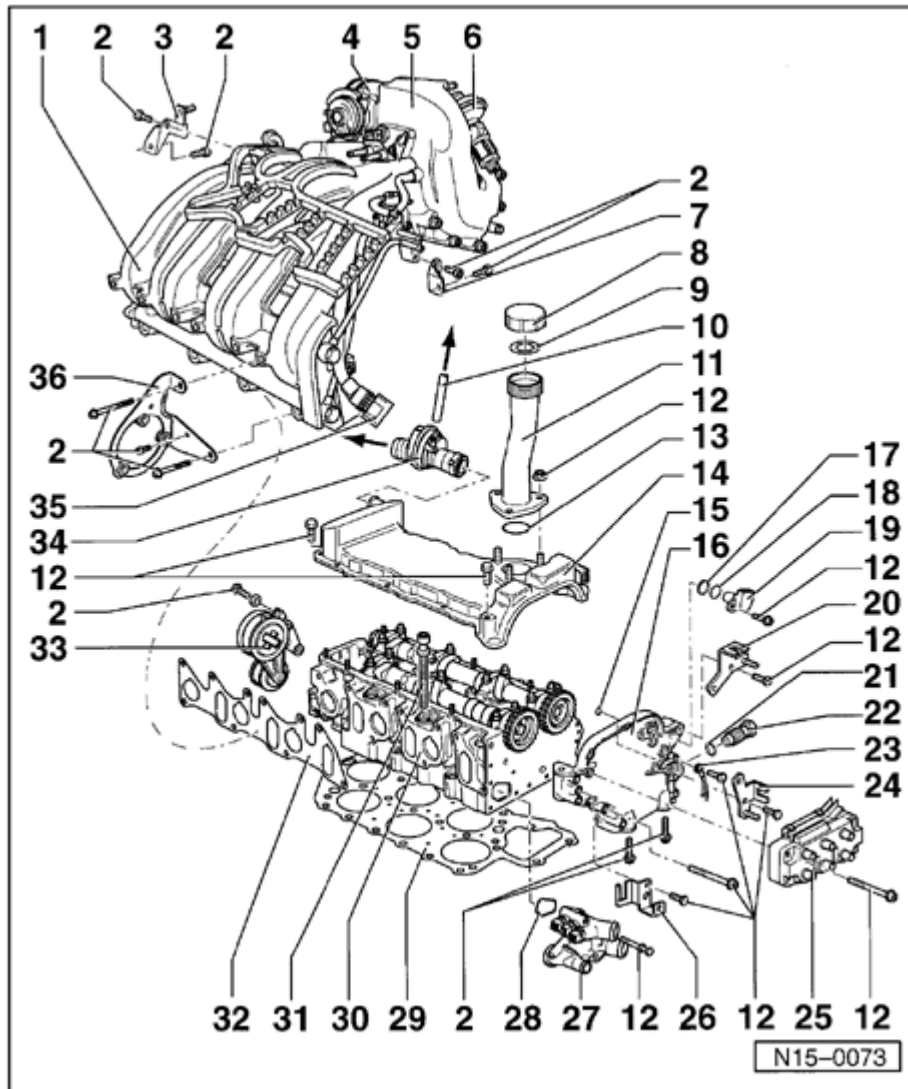

28 - O-ring

- Replace

29 - Cylinder head gasket

- Replace.

- If replaced, replace all engine coolant.

30 - Cylinder head

- Check for distortion ⇒ [Fig. 1](#) .

◆ Installing ⇒ [Page 15-17](#)

- If replaced, replace all engine coolant.

- Note sequence when loosening and tightening ⇒ [Page 15-17](#) .

31 - Cylinder head bolt

- Replace.

- Note sequence when loosening and tightening ⇒ [Page 15-17](#) .

32 - Lower intake manifold gasket

- Replace

- Note installed position.

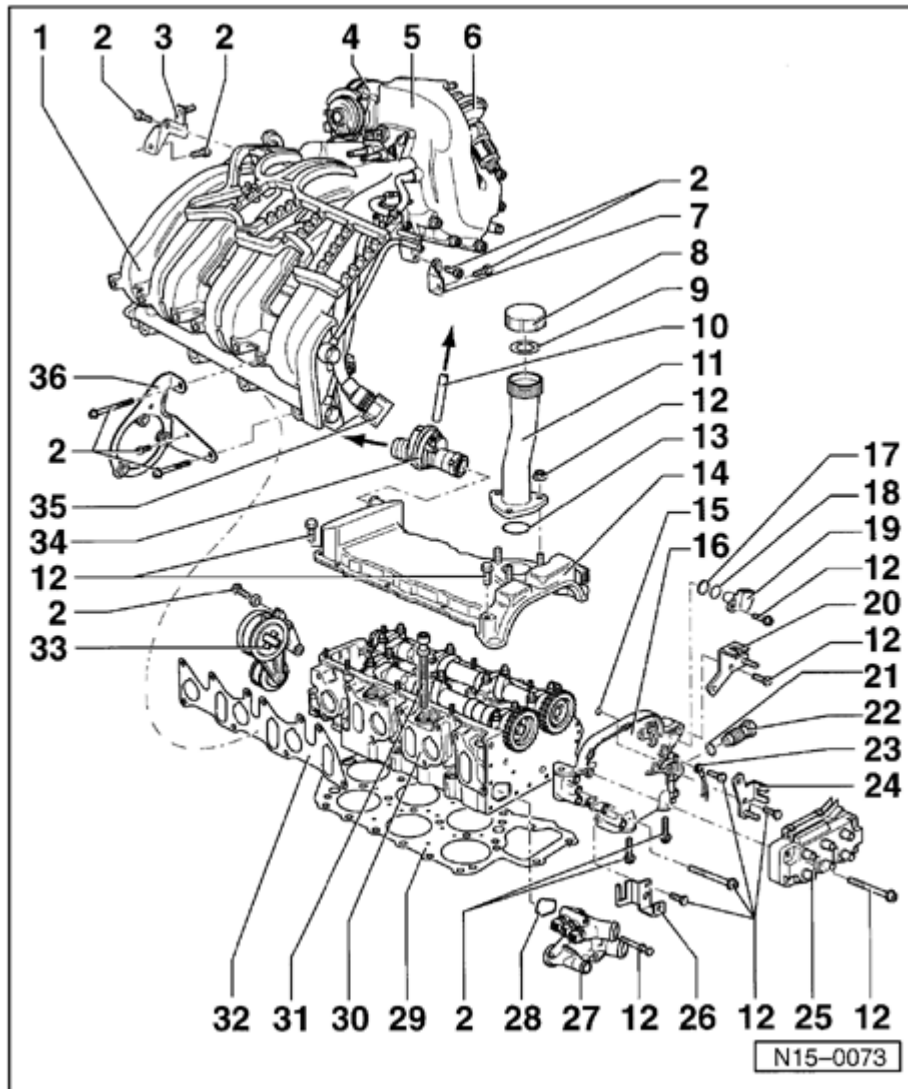

33 - Ribbed belt tensioner

- ◆ Ribbed belts, removing and installing ⇒ [Page 13-22](#)

34 - Positive Crankcase Ventilation valve

- ◆ Arrow on valve points toward intake hose:
⇒ [Repair Manual, 2.8 Liter VR6 2V Fuel Injection & Ignition, Engine Code\(s\): AES, Repair Group 24](#)

35 - Connector

- ◆ For injectors -N30-, -N31-, -N32-, -N33-, -N83-, -N84-
- ◆ Mounted to bracket (item 26)

36 - Retainer

- ◆ For Secondary Air Injection pump motor ⇒ [Page 26-14](#)

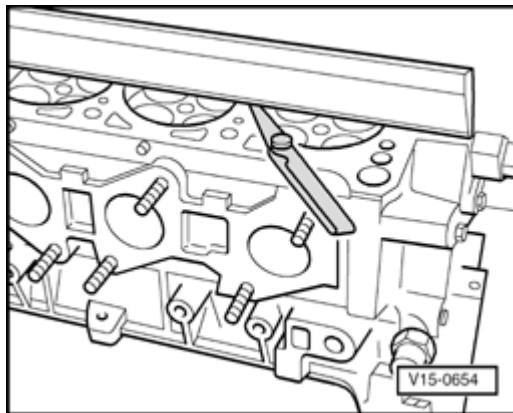

A Fig. 1 Cyl. head, checking for distortion

Special tools and equipment

- ◆ Feeler gauge set

Max. permissible distortion: 0.1 mm

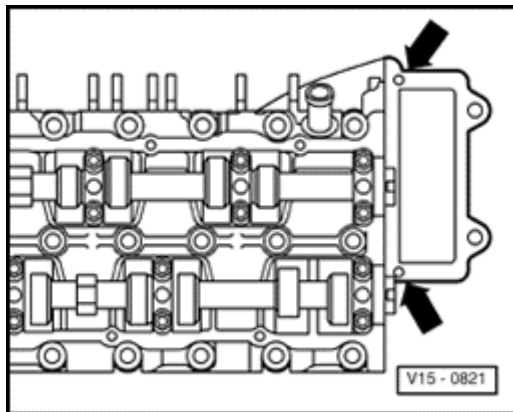

A Fig. 2 Cyl. head gasket, preparing for assembly

Special tools and equipment

- ◆ AMV 188 001 02 sealant
- Remove old sealant from 3 mm holes in cylinder head gasket -arrows-.
- Fill 3 mm holes in cylinder head gasket using sealant AMV 188 001 02.

Note:

When cylinder head is installed, holes are only half visible.



Cylinder head cover, removing and installing

Special tools and equipment

- ◆ 3277A installation tool
- ◆ VAG 1331 Torque wrench 5 to 50 Nm (4 to 37 ft. lb)
- ◆ VAG 1921 spring clip pliers

Removing

CAUTION!

Obtain radio code before disconnecting battery ground strap.

- Switch OFF ignition.
- Disconnect battery ground strap.
- Replace all cable ties removed to remove engine, and place them in their original position.
- Remove sound tray.

⇒ [Repair Manual, Body Exterior, Repair Group 50](#)

- Remove radiator grille.

⇒ [Repair Manual, Body Exterior, Repair Group 66](#)

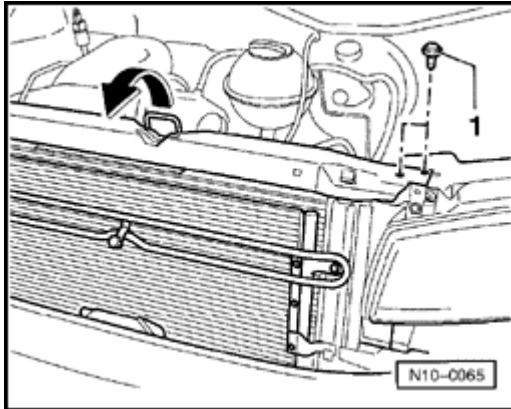

A

- Remove lock carrier bolts -1- on left and right side.
- Pivot lock carrier forward (with radiator) -arrow-.
- Disconnect heater element connector (on intake hose) .
- Remove intake hose between upper air cleaner and Throttle Valve Control Module -J338- together with Positive Crankcase Ventilation valve.

⇒ [Repair Manual, 2.8 Liter VR6 2V Fuel Injection & Ignition, Engine Code \(s\): AES, Repair Group 24](#)

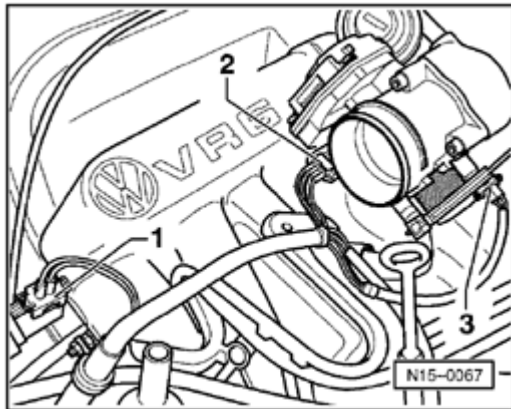

A

- Disconnect connectors from EGR valve -1-, Throttle Valve Control module -2-, and Intake Air Temperature Sensor (ATS) -G72- -3-.

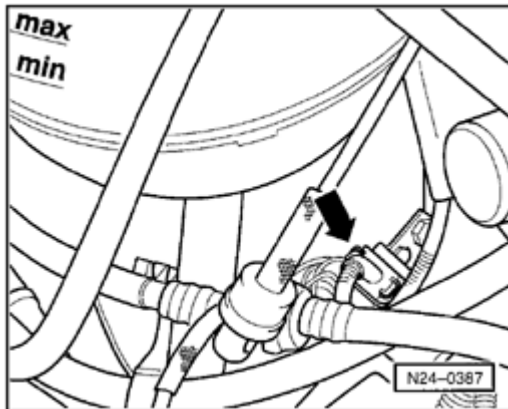

A

- If equipped, disconnect 2-pin connector from EGR Temperature sensor -arrow-.

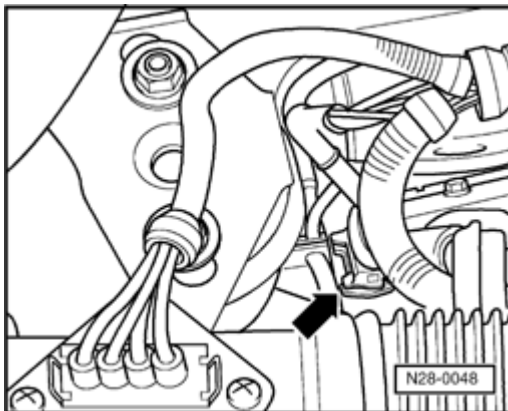

A

- Disconnect white 3-pin connector from Knock sensor 1 -arrow-.
- Release wiring from clips behind intake manifold and on EGR valve.
- Remove spark plug connectors using 3277A release tool and unclip ignition cables from ignition cable guides.

⇒ [Repair Manual, 2.8 Liter VR6 2V Fuel Injection & Ignition, Engine Code \(s\): AES, Repair Group 28](#)

- Detach accelerator cable (do not remove locating clip) from support bracket and Throttle Valve Control Module .

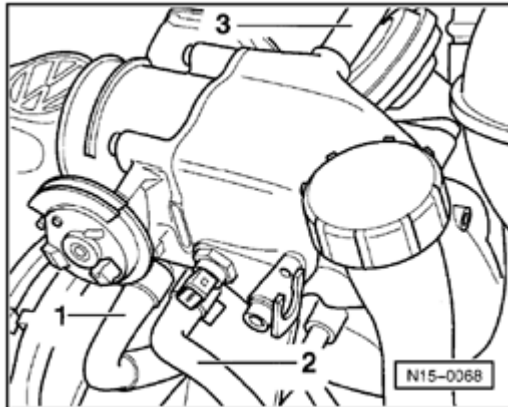

A

- Mark coolant hoses -1- and -2- from Throttle Valve Control Module.
- Pull off hoses using VAG 1921 hose clamp pliers (after first releasing pressure from cooling system).
- Seal coolant hoses.
- Remove breather hose from EVAP canister purge regulator valve -3-.
- Disconnect vacuum hose to brake servo from intake manifold.

WARNING!

Fire Hazard. Do NOT smoke or have anything in area that can ignite fuel.

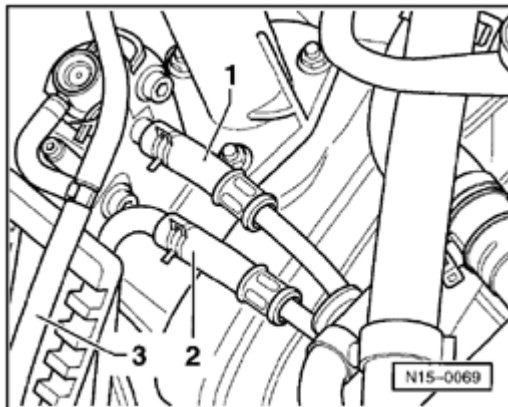

A

- Using VAG 1921 hose clamp pliers, remove fuel return line -1- (blue or blue markings) and fuel supply line -2- (black or black markings).

WARNING!

Fuel supply lines are under pressure! Before disconnecting line connections wrap a cloth around connection, then release pressure by carefully pulling hose connection.



- Disconnect vacuum hose -3- from Secondary Air Injection valve from junction piece.
- Disconnect line from exhaust manifold at EGR valve connection.
- Disconnect fuel injector connectors and remove connector from retaining bracket.

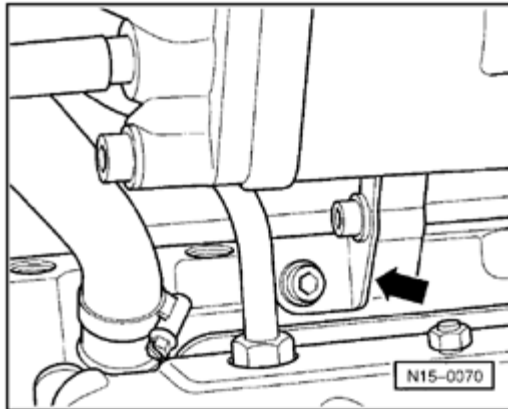

A

- Remove left rear support between intake manifold and cyl. head - arrow-.

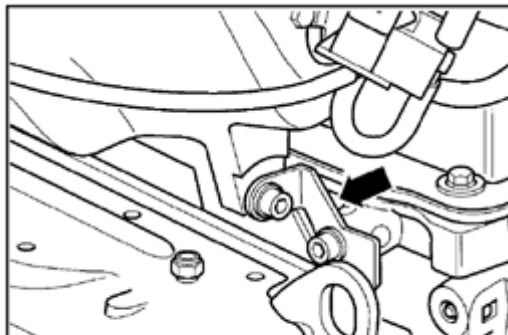

A

- Remove right rear support between intake manifold and cyl. head - arrow-.

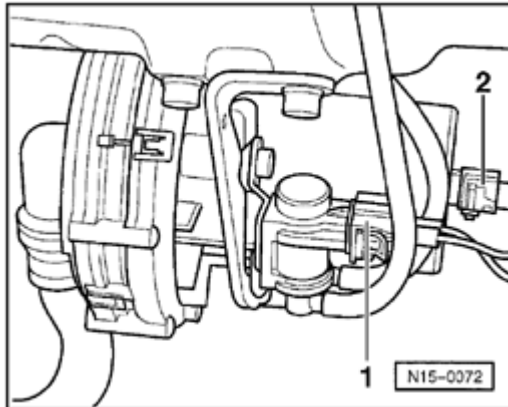

A

- Disconnect Secondary Air Injection system valve -1- and Secondary Air Injection system pump motor -2-.
- Remove Secondary Air Injection pump motor ⇒ [Page 26-14](#) .
- Remove Secondary Air Injection combi-valve ⇒ [Page 26-19](#) .
- Remove combi-valve connection at cylinder head ⇒ [Page 26-14](#) .
- Remove dipstick guide tube.
- Remove intake manifold bolts.
- Remove intake manifold assembly/Throttle Valve Control Module.
 - ◆ When installing, note position of dowel sleeves in cyl head.

Note:

Seal dipstick guide tube opening in cylinder block and intake ports in cylinder head using a clean cloth.

- Remove cylinder head cover.



Cylinder head, installing

- Install components in reverse sequence.

Note:

- ◆ *Replace cylinder head cover if damaged or leaking.*
- ◆ *Replace gasket between lower intake manifold and cylinder head cover.*
- ◆ *First tighten intake manifold (including lower intake manifold) to cylinder head, then tighten both rear supports.*
- ◆ *Fuel lines must be tight.*
- Replace engine coolant ⇒ [Page 19-14](#) .
- Adjust throttle cable ⇒ [Page 26-19](#) .
- Check Diagnostic Trouble Code (DTC) memory.

⇒ [Repair Manual, 2.8 Liter VR6 2V Fuel Injection & Ignition, Engine Code\(s\): AES, Repair Group](#)



Tightening torques

Bolted joints	Tightening torque
Cylinder head cover to cylinder head	10 Nm (7 ft. lb)
Lower intake manifold to cylinder head	25 Nm (18 ft. lb)
Right and left rear supports to intake manifold and cylinder head	25 Nm (18 ft. lb)
Line to EGR valve connection	30 Nm (22 ft. lb)



Cylinder head, installing

Special tools and equipment

- ◆ VAG 1332 Torque wrench 40 to 200 Nm (30 to 148 ft. lb)
- ◆ 3268 Crankshaft setting bar

Work sequence

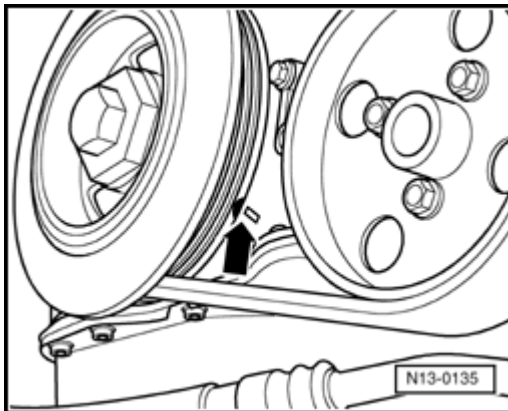
**A**

- Set crankshaft to TDC cyl. 1 mark -arrow- by turning crankshaft with vibration damper bolt in direction of engine rotation.

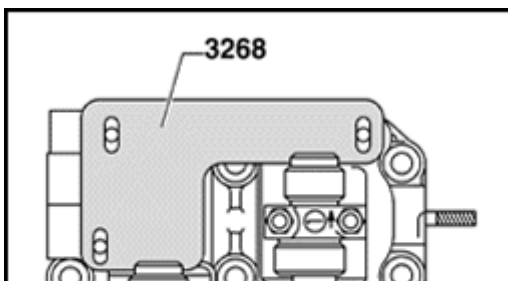
**A**

- Position camshafts using 3268 camshaft bar.

Note:

This position is only possible every 2nd TDC position.

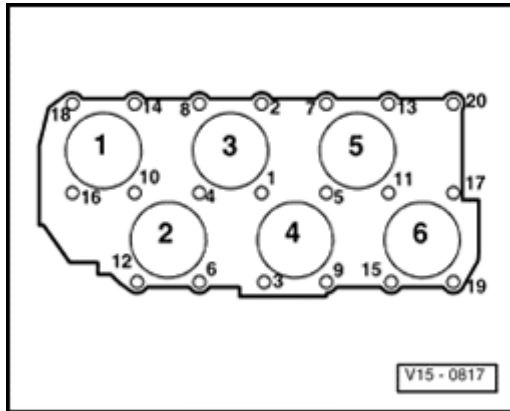

A

- Install cylinder head gasket.
 - ◆ Note position of locating pins (in block holes 12, 20).
- Install cylinder head.
- Insert cylinder head bolts and tighten by hand.
- Tighten cylinder head using four stage sequence as follows:
- Tighten initially using torque wrench
 - ◆ Stage I = 40 Nm (30 ft. lb)
 - ◆ Stage II = 60 Nm (44 ft. lb)
- Turn further using ordinary wrench
 - ◆ Stage III = additional $\frac{1}{4}$ turn
 - ◆ Stage IV = additional $\frac{1}{4}$ turn

Note:

- ◆ *Loosening cylinder head: reverse sequence.*
- ◆ *Torquing cylinder head after repairs is not necessary.*



Cylinder compression, checking

Special tools and equipment

- ◆ VAG 1763 Compression tester
- ◆ 3122 B Spark plug wrench
- ◆ 3277 Installation tool

Test conditions

- ◆ Engine oil temperature 30 ° C (86 ° F) minimum.

Work sequence

- Remove radiator grille.

⇒ [Repair Manual, Body Exterior, Repair Group 66](#)

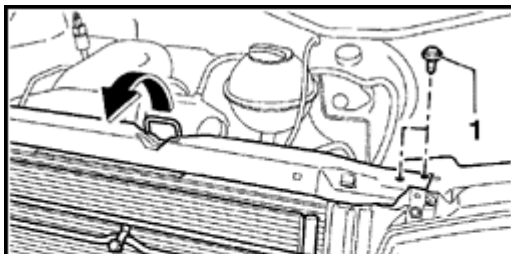

A

- Remove left and right screws.
- Pivot lock carrier forward (with radiator) -arrow-.
- Disconnect heater element connector and remove intake hose between upper Air Cleaner and Throttle Valve Control Module -J338- together

with Positive Crankcase Ventilation valve.

⇒ [Repair Manual, 2.8 Liter VR6 2V Fuel Injection & Ignition, Engine Code \(s\): AES, Repair Group 24](#)

- Remove spark plug connectors using 3277 A tool. Unclip ignition cables.

⇒ [Repair Manual, 2.8 Liter VR6 2V Fuel Injection & Ignition, Engine Code \(s\): AES, Repair Group 28](#)

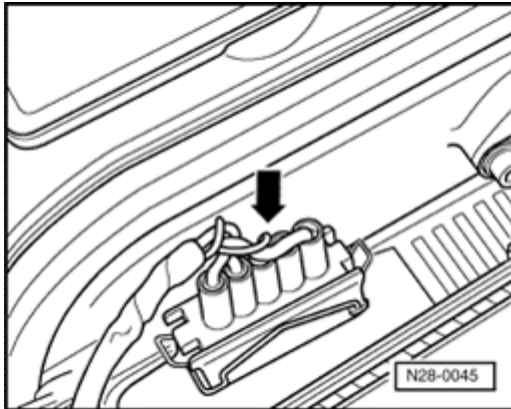

- Remove spark plugs with 3122 B spark plug wrench.

A

- Disconnect 5-pin connector from ignition coil -arrow-.
- Hold throttle valve open.
- Check compression using VAG 1763 compression tester.

Note:

See manufacturer's instructions on how to use compression tester.

- Operate starter until tester shows no further pressure increase.

Compression checking specifications

- ◆ New: 10 to 13 bar (145 to 189 psi)
- ◆ Wear limit: 7.5 bar (109 psi)
- ◆ Permissible difference between cylinders: 3 bar (44 psi)